



# Assembly Instructions

## Asher Square Corner Seating Unit

(Product Codes: 69014018)

















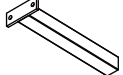

PLEASE RETAIN THIS DOCUMENT ALONG WITH YOUR  
PROOF OF PURCHASE FOR FUTURE

Congratulations on your recent purchase of your beautiful Hartman furniture. We hope it brings you bountiful special moments with friends and family for many years to come. Please follow these simple steps to build your furniture. We also have a very useful video available online to assist with the assembly, please visit [www.hartmanuk.com](http://www.hartmanuk.com).

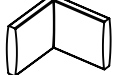

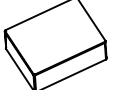

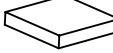





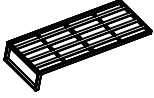



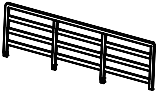

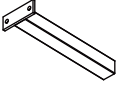
### TOP TIPS

- Please read these instructions carefully before assembly, for further assistance please view our assembly video online for an easy step by step demonstration
- Aluminum is a soft metal and over tightening may strip the thread or break the part, please loosely assembly your furniture before tightening to secure.
- Please do not use power tools, please use the allen key provided in the bolt pack
- Please allow 5 minutes for assembly
- This furniture can be assembled with 2 persons; however, you may need someone to assist you when turning the furniture over into position.

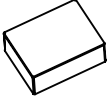
## PARTS LIST - RH SOFA

Components					Fixings				
Parts List	Parts Picture	Description	Qty	Part no	Parts List	Parts Picture	Description	Qty	Part no
A		Seat Frame 1	1	69014018A	M		Washer (M6*φ16)	10	1061162
B		Armrest1	1	69014018B	N		Bolt (M6X20)	2	1091162
C		Back Rest 1	1	69014018C	O		Bolt (M6X35)	2	1111162
D		Back Rest 2	1	69014018D	P		Bolt (M6X45)	10	1131162
E		Center support leg	1	69014018E	Q		Bolt (M6X55)	2	1641162
F		Back cushion	2	5AHBC001MG	R		Allen (M6)	2	1010162
G		Corner back cushion	1	5AHCB001MG	S		Plastic bolt cap (M6)	16	1061163
H		Seat cushion	2	5AHSC001MG	T		Washer (M6*φ12)	2	1241162
I		Corner seat cushion	1	5AHCS001MG	U		Lock washer (M6)	16	1051163
					V		Velcro	2	2200011

## PARTS LIST - LH SOFA

Components					Fixings				
Parts List	Parts Picture	Description	Qty	Part no	Parts List	Parts Picture	Description	Qty	Part no
J		Seat Frame 2	1	69014018J	M		Washer (M6*φ16)	8	1061162
K		Armrest 2	1	69014018K	N		Bolt (M6X20)	2	1091162
L		Back Rest 3	1	69014018L	O		Bolt (M6X35)	2	1111162
E		Center support leg	1	69014018E	P		Bolt (M6X45)	4	1131162
F		Back cushion	2	69014018F	Q		Bolt (M6X55)	2	1641162
H		Seat cushion	2	69014018H	R		Allen (M6)	2	1010162
					S		Plastic bolt cap (M6)	10	1061163
					T		Washer (M6*φ12)	2	1241162
					U		Lock washer (M6)	10	1051163
					W		Connector Bracket	1	1051164

## STEP 1 -4: ARMREST AND LEG ASSEMBLY - RIGHTSIDE

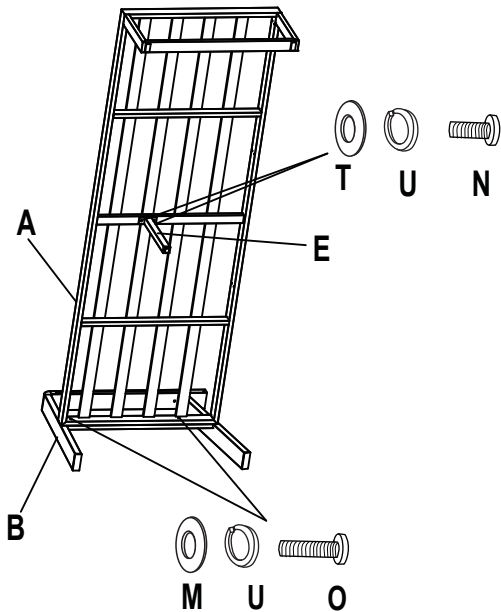

**STEP 1:** Attach Armrest 1 (B) to the Seat Frame 1 (A) using the M6x35 Bolt (c), Lock washer (U) and Washer (M).  
 Attach Center support leg (E) to the Seat Frame 1 (A) using the M6x20 Bolt (N), Lock washer (U) and Washer (T)

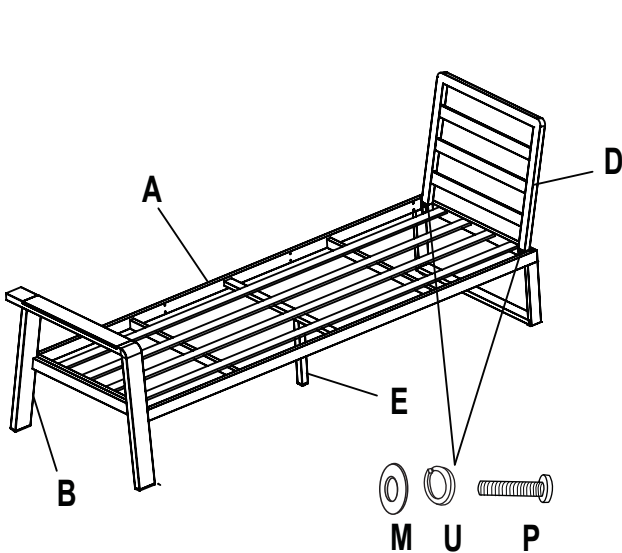

**STEP 2:** Attach Back Rest 2 (D) to the Seat Frame 1 (A) using the M6x45 Bolt (P), Lock washer (U) and Washer (M)

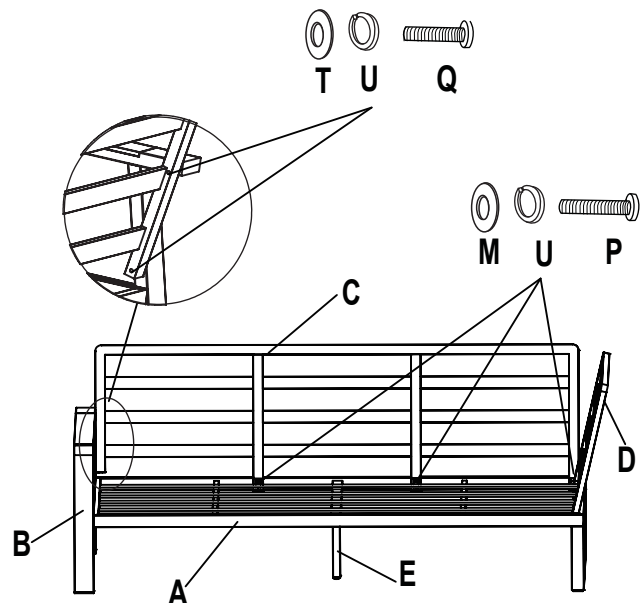

**STEP 3:** Attach Back board 1 (E) to Seat Frame1 (A) using the M6x45 Bolt (d), Lock washer (U) and Washer (M).  
 Attach Back Rest 1 (C) to the Armrest 1 (B) using the M6x55 Bolt (Q), Lock washer (U) and Washer (T)

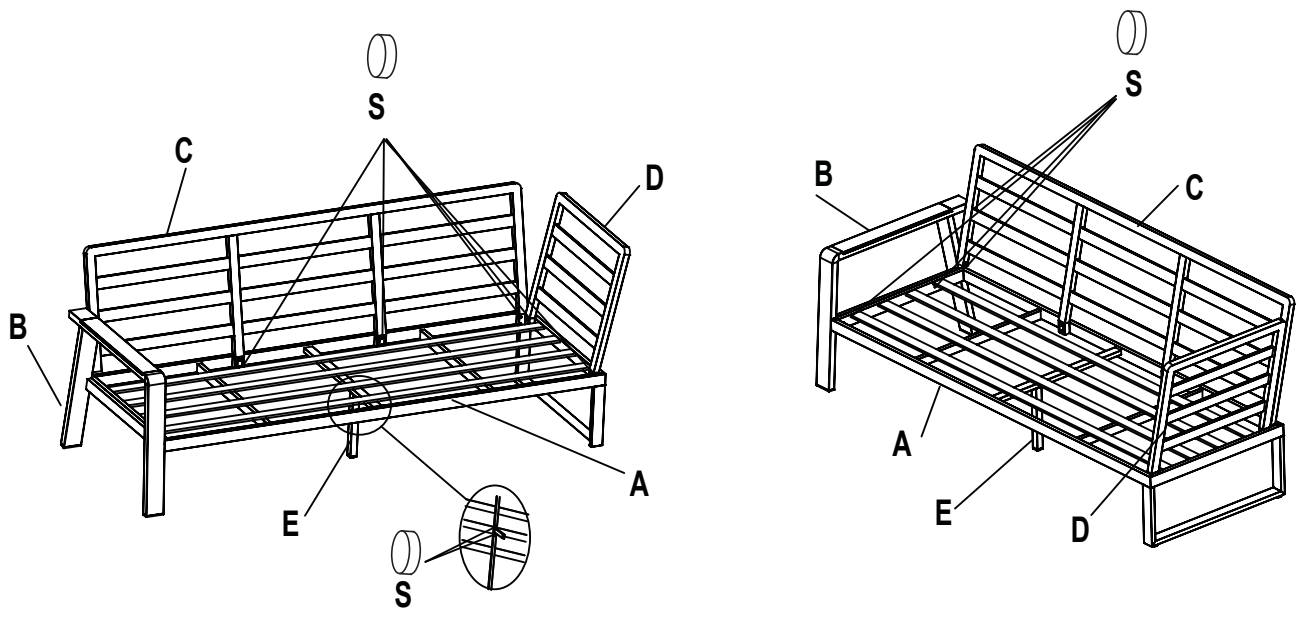

**STEP 4:** Tighten all the bolts on the rightside sofa and cover with the Plastic bolt cap (S). Turn the sofa over.

**STEP 5 to 9: ARMREST AND LEG ASSEMBLY - LEFTSIDE**

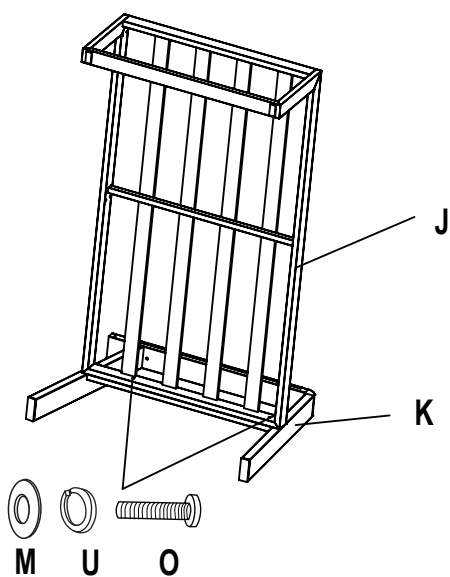

**STEP 5:** Attach Armrest 2 (K) to the Seat Frame 2 (J) using the M6x35 Bolt (O), Lock washer (U) and Washer (M)

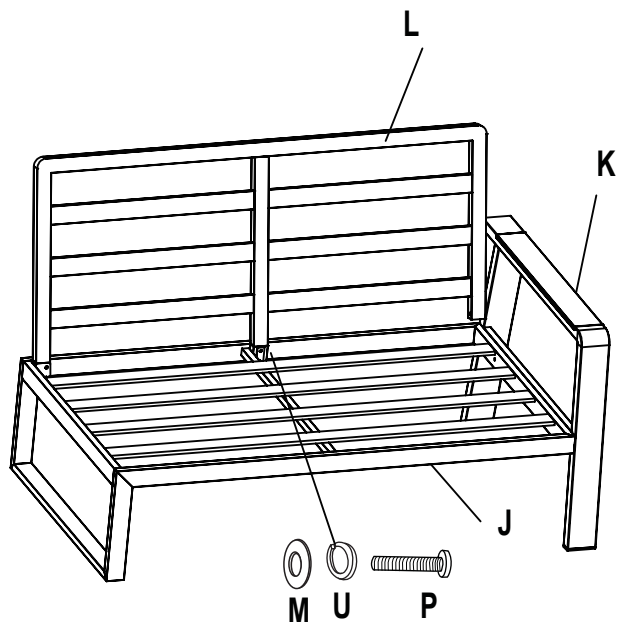

**STEP 6:** Attach Back Rest 3 (L) to the Seat Frame 2 (J) using the M6x45 Bolt (P), Lock washer (U) and Washer (M)

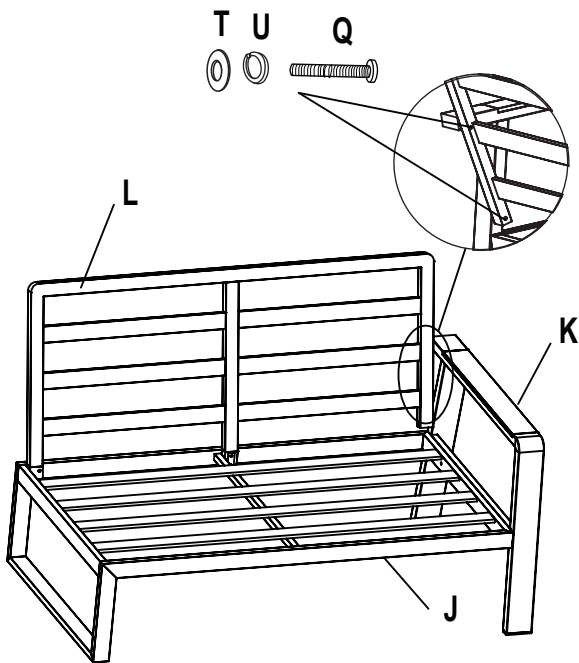

**STEP 7:** Attach Back Rest 3 (L) to the Armrest 2 (K) using the M6x55 Bolt (Q), Lock washer (U) and Washer (T)

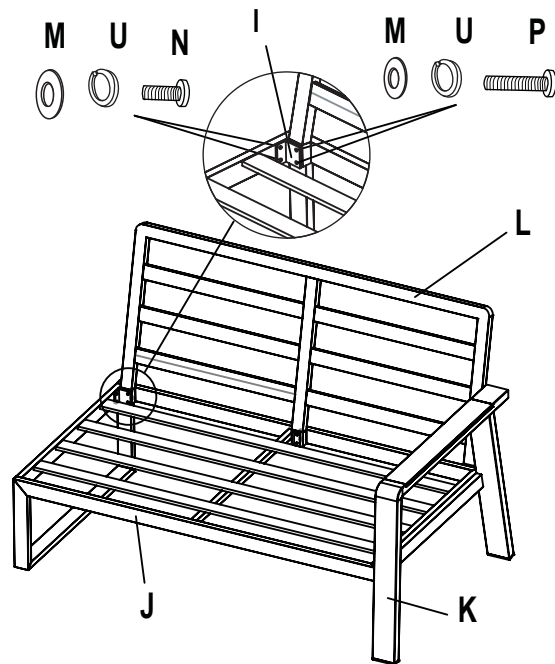

**STEP 8:** Attach the Connector Bracket (I) to Back Rest 3 (L), on one side using the M6x45 Bolt (P), Lock washer (U) and Washer (M). Secure on the other side of the Connector Bracket using the M6x20 Bolt (N), Lock washer (U) and Washer (M)

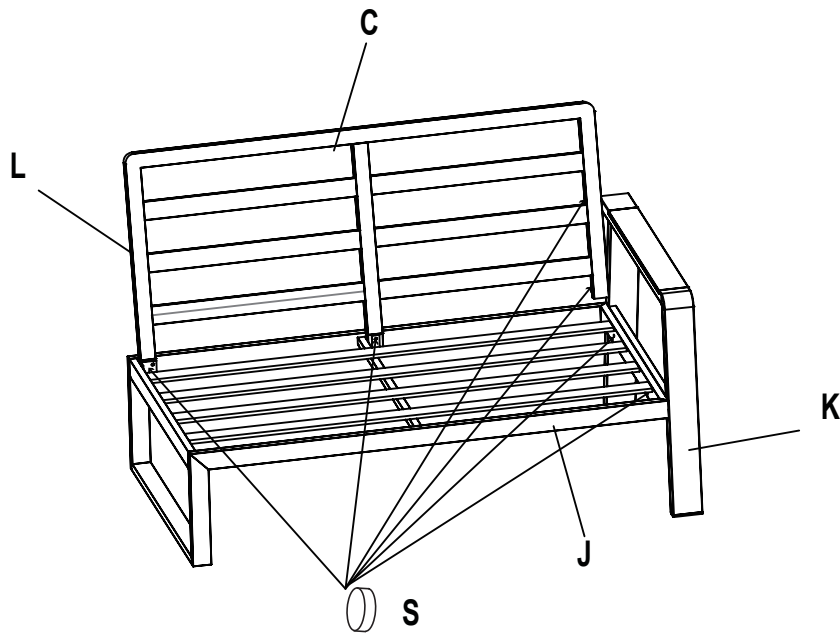

**STEP 9:** Tighten all the bolts on the left side sofa and cover with the Plastic bolt cap (S). Turn the sofa over.

## STEP 10: TIGHTEN AND FINISHING

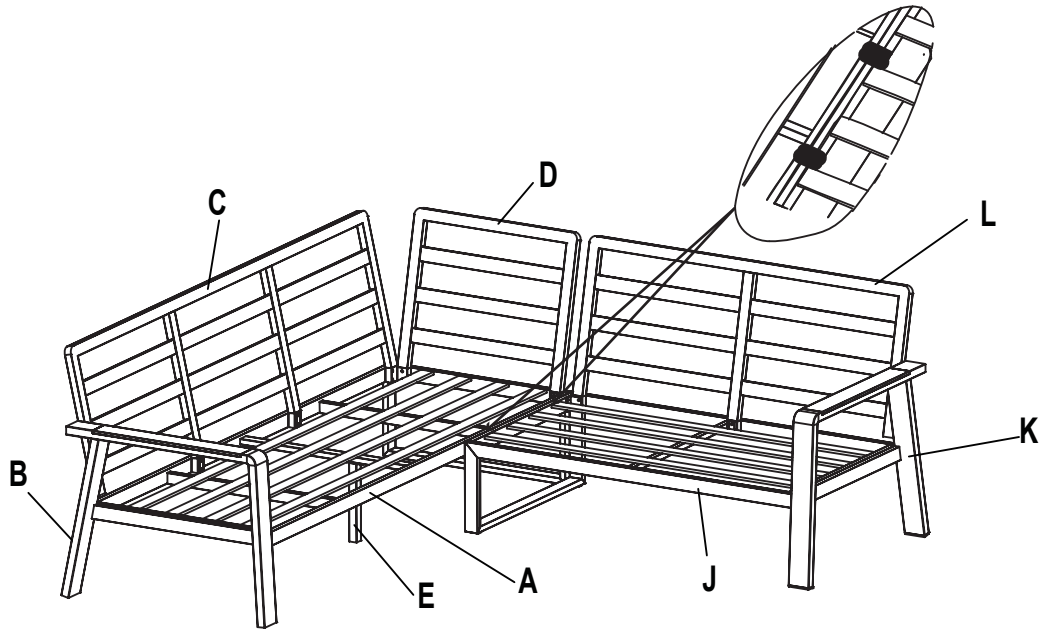

**STEP 10:** Fixed the rightside and leftside sofa using the Velcro (V). Place the Seat cushion (H) , Corner seat cushion (I), Back cushion (F) and the Corner back cushion (G) onto the sofa



# Assembly Instructions

## Asher Square Adjustable Table

(Product Codes: 69012018&69013018)

PLEASE RETAIN THIS DOCUMENT ALONG WITH YOUR  
PROOF OF PURCHASE FOR FUTURE









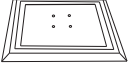

Congratulations on your recent purchase of your beautiful Hartman furniture. We hope it brings you bountiful special moments with friends and family for many years to come. Please follow these simple steps to build your furniture. We also have a very useful video available online to assist with the assembly, please visit [www.hartmanuk.com](http://www.hartmanuk.com).

### TOP TIPS

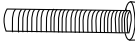
- Please read these instructions carefully before assembly, for further assistance please view our assembly video online for an easy step by step demonstration
- Aluminum is a soft metal and over tightening may strip the thread or break the part, please loosely assembly your furniture before tightening to secure.
- Please **do not** use power tools, please use the allen key provided in the bolt pack
- Please allow 5 minutes for assembly
- This furniture can be assembled with **2** persons; however, you may need someone to assist you when turning the furniture over into position.



# PARTS LIST

Components					Fixings				
Parts List	Parts Picture	Description	Qty	Part no	Parts List	Parts Picture	Description	Qty	Part no
A		Base	1	69012018A	D		Bolt (M6X25)	4	1017162
B		Table top	1	69012018B	E		Bolt (M6X35)	2	1111162
C		Gas pump	1	69013018C	F		Bolt (M8X50)	4	1012162
					G		Washer (M6)	6	1061162
					H		Washer (M8)	4	1062162
					I		Plastic bolt cap (M6)	6	1061163
					J		Plastic bolt cap (M8)	4	1061164
					K		Allen (M6)	1	1010162
					L		Allen (M8)	1	1051162

## STEP 1 & 2: GAS PUMP ASSEMBLY

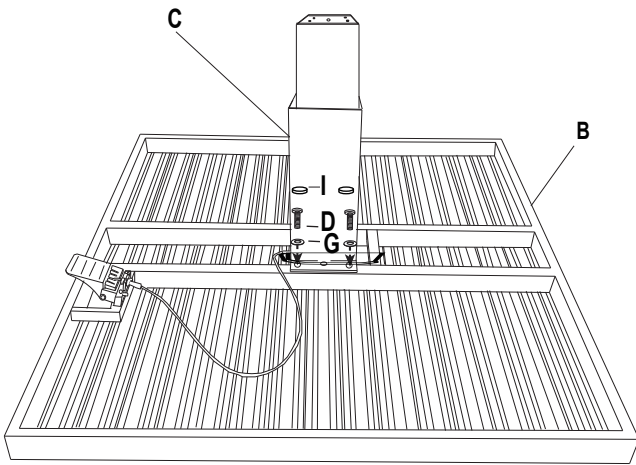

**STEP 1:** Attach Gas pump (C) to the Table top (B), using the M6x25 Bolt (D) and Washer (G). Tighten all the bolts with Allen (K), and cover with the Plastic bolt cap (I).

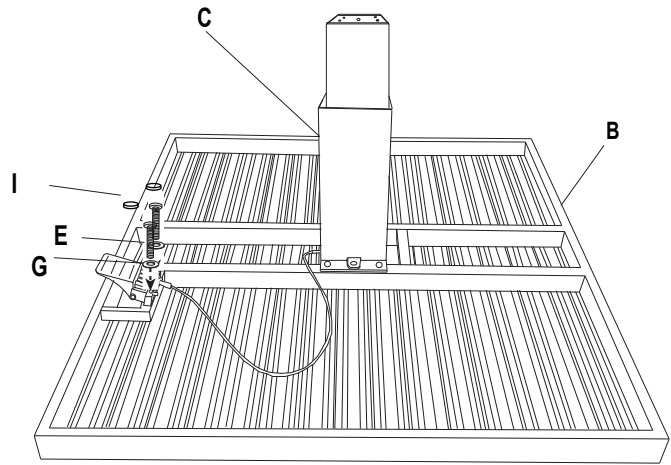

**STEP 2:** Attach handle to the Table top (B), using the M6x35 Bolt (E) and Washer (G). Tighten all the bolts with Allen (K), and cover with the Plastic bolt cap (I).

## STEP 3: BASE ASSEMBLY

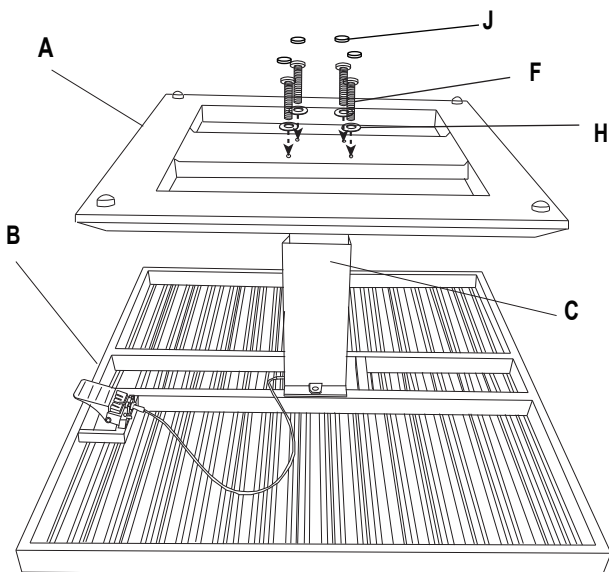

**STEP 3:** Attach Base (A) to the the Gas pump(C), using the M8x50 Bolt (F) and Washer (H). Tighten all the bolts with Allen (K), and cover with the Plastic bolt cap (J).

## STEP 4 & 5: COMPLETE AND TRY LIFT FUNCTION

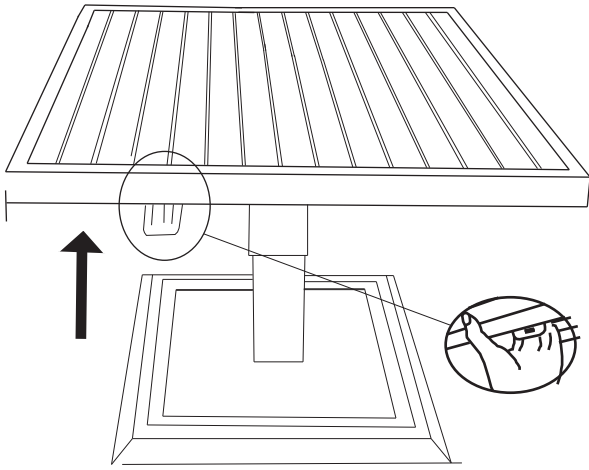

**STEP 4:** Turn the Table over. Squeeze the handle to raise the table top

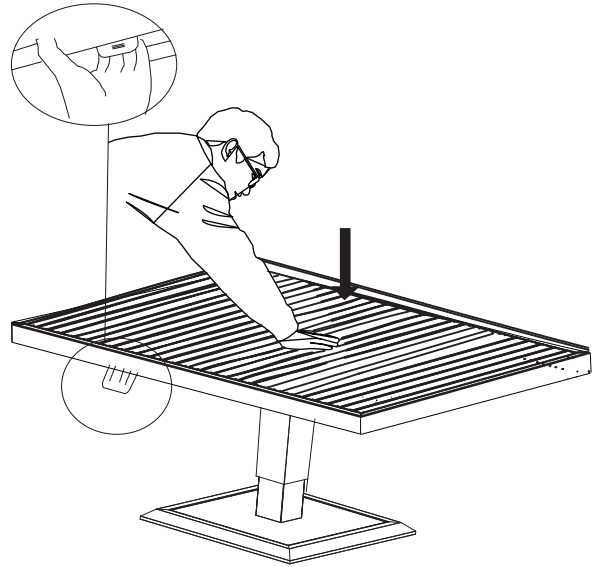

**STEP 5:** Press down in the center of Table top while squeezing the handle to lower the table top